

DN10/15 - 50

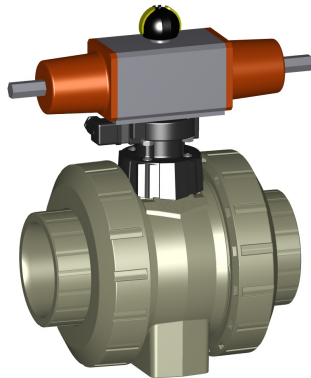

Kulový kohout typ 231 PROGEF Standard FO (Bez tlaku otevřeno), bez ručního ovládání S nátrubky pro polyfúzní svařování metric

Provedení:

- Materiál: **PP-H**
- Řídicí čas 90°< 1-2 s
- Přirazení pohonů: PA11 (DN10/15-25), PA21 (DN32-50), PA30 (DN65), PA40 (DN80), PA40 (DN100)
- Snadná montáž a demontáž
- Integrované nerezové montážní závity

Možnosti:

- Individuální konfigurace armatury

d	DN	PN	kv-hodnota	EPDM	SP	Váha	FKM	SP	Váha
(mm)	(mm)	(bar)	(l/min)	kód		(kg)	kód		(kg)
16	10	10	70	199 231 162	1	1.200	199 231 172	1	1.200
20	15	10	185	199 231 163	1	1.200	199 231 173	1	1.200
25	20	10	350	199 231 164	1	1.300	199 231 174	1	1.300
32	25	10	700	199 231 165	1	1.151	199 231 175	1	1.400
40	32	10	1000	199 231 166	1	2.500	199 231 176	1	2.500
50	40	10	1600	199 231 167	1	2.800	199 231 177	1	2.800
63	50	10	3100	199 231 168	1	3.700	199 231 178	1	3.700
75	65	10	5000	199 231 169	1	6.600	199 231 179	1	6.600
90	80	10	7000	199 231 170	1	8.400	199 231 180	1	8.400
110	100	10	11000	199 231 171	1	12.600	199 231 181	1	12.600

d	D	H	H1	H2	H5	L	L1	L2	L4	L5	L6	L7	z	Nejbl. inch (inch)
(mm)	(mm)	(mm)	(mm)	(mm)	(mm)	(mm)	(mm)	(mm)	(mm)	(mm)	(mm)	(mm)	(mm)	
16	50	159	27	62	77	93	194	56	25	261	76	48	66	¾
20	50	159	27	62	77	95	194	56	25	261	76	48	67	½
25	58	168	30	71	77	108	194	65	25	261	76	48	77	¾
32	68	168	36	71	77	118	194	71	25	261	76	48	83	1
40	84	202	44	84	99	137	224	85	45	305	95	59	99	1 ¼
50	97	202	51	84	99	147	224	89	45	305	95	59	105	1 ½
63	124	225	64	106	99	168	224	101	45	305	95	59	117	2
75	166	262	85	156	70	233		136	70	276	65		167	2 ½
90	200	281	105	168	78	254		141	70	341	72		180	3
110	238	292	123	175	86	301		164	120	369	80		215	4

